



reventon

INDUSTRIAL SOLUTIONS

Technical documentation

DESTRATIFICATION FAN TORNADO SERIES

MODELS:

TORNADO XS1
TORNADO XS2
TORNADO XS3
TORNADO XS4
TORNADO XS5
TORNADO XS6



1. INTRODUCTION

- 1.1 PRECAUTIONS
- 1.2 TRANSPORT
- 1.3 PACKAGE CONTENT
- 1.4 USE

2. DEVICE CHARACTERISTICS

- 2.1 CONSTRUCTION AND PRINCIPLE OF OPERATION
- 2.2 DEVICE DIMENSIONS
- 2.3 DEVICE TECHNICAL DATA

3. ASSEMBLY

- 3.1 GENERAL PRINCIPLES
- 3.2 MOUNTING HOLES

4. INSTALLATION INSTRUCTIONS

- 4.1 CONNECTION OF THE DEVICE TO THE ELECTRICAL SYSTEM

5. PRECAUTIONS & WARNINGS

6. CONTROLS

7. CONNECTION SCHEMES

8. TERMS OF WARRANTY

1. INTRODUCTION

Thank you very much for purchasing destratification fan TORNADO. We would like to congratulate you on excellent choice. Please read and keep this manual.

1.1 PRECAUTIONS

The buyer and the user of the destratification fan Reventon Group brand should read carefully the following instructions and proceed to the content recommendations. Proceeding due to the following instruction guarantees the correct usage and safety. In case of any doubts please contact directly Reventon Group Sp. z o.o. [Ltd.]. The producer reserves the rights to make changes to the technical documentation without previous notice. Reventon Group Sp. z o.o. [Ltd.] is not responsible for the damages which occur due to improper installation, not keeping the device in repair or using the device out of line. The installation should be carried out by the professional installers, who possess the qualifications to install these types of devices. The installers are responsible for making the installation as instructed in the technical data. In case of unserviceable please plug out the device and contact with the authorized for repair person or the supplier. During the installation, use, service and periodical inspections all regulations and safety rules must be followed.

1.2 TRANSPORT

During the acceptance of goods, it is needed to check the device to exclude any damages. During the transport, it is needed to use the proper equipment, it is necessary to carry the device by two people. In case of any damages please fill in the damage report in presence of the supplier.

1.3 PACKAGE CONTENT

- destratification fan
- instruction and warranty card

1.4 USE

In the heated high large-spaces the air mass is located in the upper part of room, which causes the heat loss. Destratification fans also called the drop fans or air mixers are used to save on heating. They steer the air back to work zone at the same time they level out the air temperature in the high room, they also limit the heat loss through the roof. They are used in production halls, warehouses and logistic centres.

2. DEVICE CHARACTERISTICS

2.1 CONSTRUCTION AND PRINCIPLE OF OPERATION

Cylindrical casing: made of galvanized steel. It has mounting holes which make it easy to assemble the destratification fan with e.g. mounting rods.

Diffuser 360°: made of galvanized steel. Using specially shaped air stators the diffuser enables even air distribution in the room.

Axial blowing fan: made of galvanized steel. It has a single-phase motor with the following parameters: protection degree IP44, rated current 0.65 - 3.5 A (depending on the model). The smallest device in the series has diameter 350 mm while the biggest one has diameter 630 mm.

2.2 DEVICE DIMENSIONS

| | Ø | h |
|-------------|-----|-----|
| TORNADO XS1 | 421 | 180 |
| TORNADO XS2 | 466 | 190 |
| TORNADO XS3 | 515 | 190 |
| TORNADO XS4 | 567 | 250 |
| TORNADO XS5 | 635 | 250 |
| TORNADO XS6 | 705 | 250 |

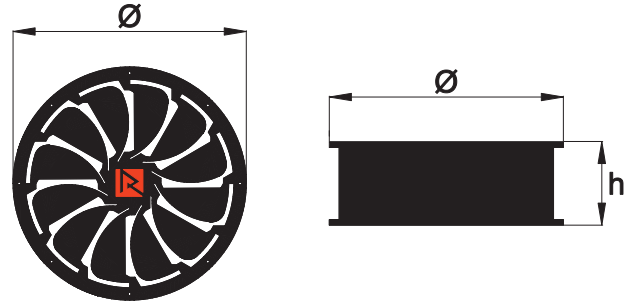

2.3 DEVICE TECHNICAL DATA

| TECHNICAL DATA | TORNADO XS1 | TORNADO XS2 | TORNADO XS3 | TORNADO XS4 | TORNADO XS5 | TORNADO XS6 |
|--|-------------|-------------|-------------|-------------|-------------|-------------|
| Product code | DT-XS1-1965 | DT-XS2-1966 | DT-XS3-1967 | DT-XS4-1968 | DT-XS5-1969 | DT-XS6-1970 |
| Maximum airflow [m3/h] | 2200 | 3600 | 4500 | 5400 | 6750 | 10200 |
| Maximum vertical range [m] | 6 | 8 | 9 | 11 | 12 | 15 |
| Supply voltage [V] / Supply frequency [Hz] | 230/50 | 230/50 | 230/50 | 230/50 | 230/50 | 230/50 |
| Rated motor current [A] | 0,65 | 0,82 | 1,15 | 1,35 | 1,75 | 2,9 |
| Motor speed [rpm] | 1420 | 1380 | 1350 | 1380 | 1380 | 1300 |
| Motor power [W] | 126 | 180 | 250 | 295 | 385 | 660 |
| Protection degree IP [-] | 44 | 44 | 44 | 44 | 44 | 44 |
| Net weight [kg] | 7,1 | 8,3 | 10,6 | 13,6 | 16,8 | 23,0 |
| Noise [dB]* | 52 | 55 | 57 | 58 | 59 | 62 |

* measurement at the distance 5 m

3. ASSEMBLY

3.1. GENERAL PRINCIPLES

During installation, ensure a free air flow to the device and do not restrict the air stream supply. The figures below show the recommended distances between the heater and building partitions:

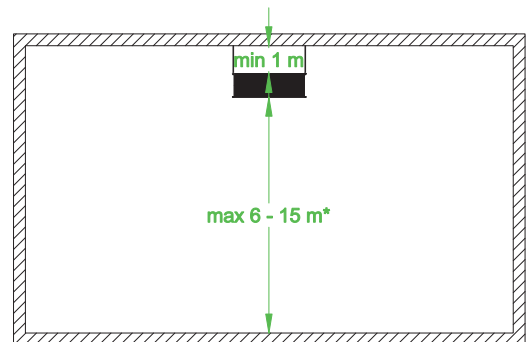

* the maximum vertical range depends on the model

3.2 MOUNTING HOLES

There are special mounting holes in the back flange of the fan. Using them, it is possible to mount the device with e. g. mounting pins. In order to dampen possible vibrations of the structure, it is recommended to use anti-vibration mounts. Necessary assembly elements, suitable for this type of installation, should be purchased independently.

4. INSTALLATION INSTRUCTIONS

4.1. CONNECTION OF THE DEVICE TO THE ELECTRICAL SYSTEM

- all works concerning electrical installation should be made by the qualified personnel (who possess required authorizations to install electrical equipment), based on wiring schematic diagrams (see 7)
- the electrical installation of the building shall have a residual current device
- it is recommended to check the electric installation and controls before the first start

5. PRECAUTIONS & WARNINGS

The precautions mentioned below must be strictly followed during operation of the device:

- all works concerning electrical installation (disassembly, repair etc.) should be made by the qualified staff, who possess the qualifications due to the domestic and local norms, regarding electrical installations
- before service or exchange of the device it is obligatory to cut off the current supply
- do not limit or cover the inlet and outlet of the device
- do not install, service the device with wet hands or barefoot
- the device should be kept out of reach of children and animals
- after operating time of the device, please utilize it concerning the local norms and regulations
- it is recommended to clean the device periodically (at least twice a year):
 - air stators, fan casing and blades clean from dirt
- failure to comply with cleaning obligations may have a negative effect on technical parameters of the device and lead to loss of warranty
- if the device is not used for a longer time and lead to loss of warranty disconnect the voltage supply
- the device is transported with the closed air stators. It is essential to open them in at least for 30% before first start:
 - opening the air stators of the diffuser 360° must be done by two hands in parallel

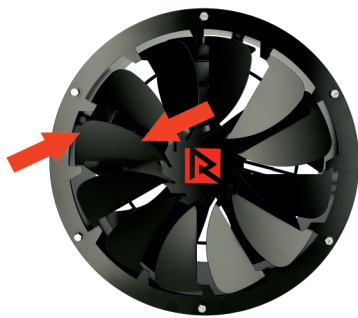

6. CONTROLS

Usage of automatic control dedicated to the devices of Reventon Group gives great possibilities of adjusting the efficiency of the unit in different, depending on needs, degree of its operation automation. We can offer the following:

Fanspeed controller HC

designed to change the single-phase fan's speed voltage controlled in industrial supply and heating systems. It is available in several versions. The selection of the appropriate model depends on the number of the devices that have to be connected to the to one regulator - the total current of the connected devices cannot exceed the maximum current flow of the regulator.



5 control levels: 80-105-135-170-230 V
Voltage/ Frequency: 230 V AC / 50 – 60 Hz
Maximum current output (depending on model):
1.2 A, 3 A, 5 A, 7 A, 14 A
Protection: thermal switch
Weight (depending on model):
1.45 kg, 2.5 kg, 4.5 kg, 5.5 kg or 10.5 kg
Degree of protection: IP 54

Manual thermostat HC

controls operation of the heater destratification fan. It switches the unit off automatically, when the set temperature is reached. The total current of the connected devices cannot exceed the maximum current flow of the thermostat.



Power supply/ Frequency: 230 V AC / 50 – 60 Hz
Maximum current: 3 A
Operating temperature: 0 - 40°C
Temperature control range: 10 - 30°C
Control accuracy: < 1°C
Degree of casing's protection: IP 30

Relay Module RM-16A

allows to connect a receiver with higher current consumption than permissible current load of connected regulator.



Power supply/ Frequency : 230 V AC / 50 – 60 Hz
Maximum rated current: 16 A
Input: NO/COM
Input: SL Connection of a regulator with the voltage relay 230 V
Dimension: 47 x 47 x 20 mm

Programmable controller HMI SINGLE

is used to regulate devices equipped with 1-stage fans. It is an advanced controller with many functions i. a. operation in heating, cooling or mixed mode, programmable mode, valve control, automatic selection of the fan speed. Together with the controller an external sensor is provided, which allows to read the temperature in the required place, even remote from the controller. In addition, the device can operate in one of two modes - thermostatic or temperature difference. The second one enables effective controlling of destratification fans. The controller can be integrated with the BMS building control system (using the MODBUS communication protocol).



Voltage/Frequency: 230 V AC / 50 – 60 Hz
Maximum current: 5 A
Operating temperature range: 0 - 45°C
Regulation range: 5°C - 35°C
Regulation accuracy: ± 0,5°C
External temperature sensor: NTC 10K
Communication: RS485
Dimensions: 86 x 86 x 13,3 mm
Weight: 270 g
Degree of protection (housing): IP 20
Degree of protection (external sensor): IP 68

7. CONNECTION SCHEMES

1. Power
2. Main switch, overcurrent circuit breaker*
3. Destratification fan TORNADO
4. Manual thermostat HC
5. Fan speed controller HC
6. Programmable controller HMI SINGLE
7. External temperature sensor

*main switch and safety fuses are not included in the set

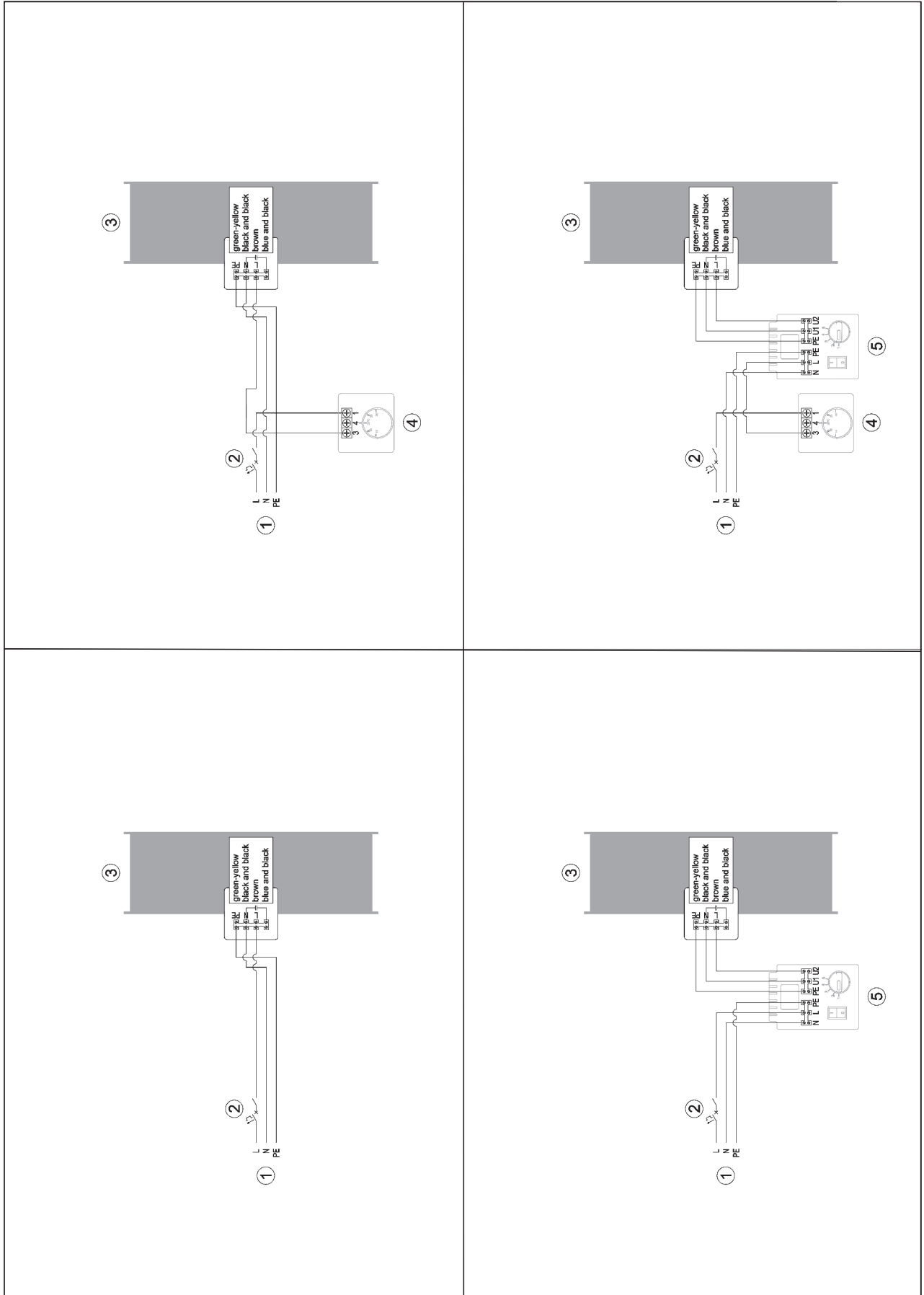

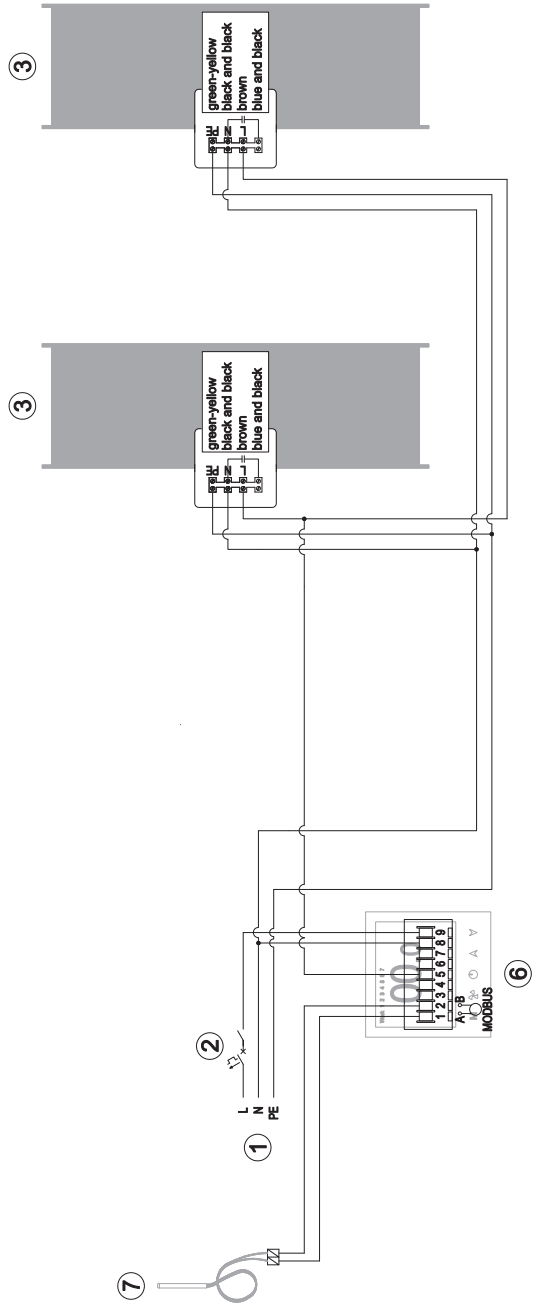
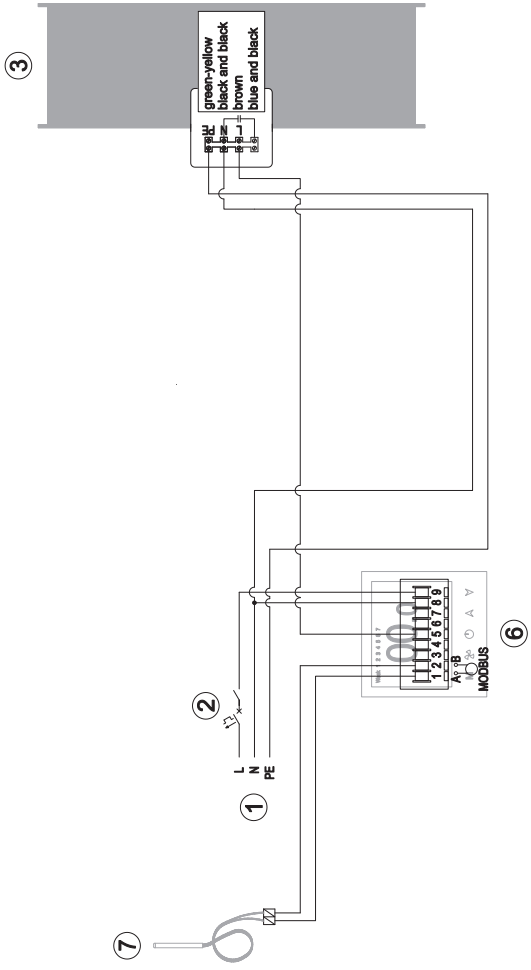

8. TERMS OF WARRANTY

I. Producer Reventon Group Sp. z o.o. [Ltd.] grants the buyer a 24-month warranty period for the following devices:

- destratification fan TORNADO XS1
- destratification fan TORNADO XS2
- destratification fan TORNADO XS3
- destratification fan TORNADO XS4
- destratification fan TORNADO XS5
- destratification fan TORNADO XS6

II. The terms of warranty are valid from purchasing the device (i.e. invoice / another confirming document issue date) but not longer than 30 months from leaving the producer's warehouse.

III. To obtain the service it is needed to provide or send to the producer scans of the warranty card with stamp of installation company, document confirming the purchase (eg. like copy of the invoice) and correctly filled the warranty form.

IV. The producer is committed to consider the claim within 14 working days since the date of reporting (i.e. day when documents given in point III are provided).

V. In the exceptional cases, the producer reserves the right to extend the time limit for examination of warranty, especially if the defect is not permanent and its determination requires a longer period of time. The extension must be notified by the producer before the end of the 14th working day.

VI. Under the guarantee the producer provides a repairment, replacement or refund for the defective device within a specified time limit.

VII. Warranty does not cover the parts of the device subject to normal maintenance and the following cases:

a) mechanical damage of the product

b) defects and damages through:

- improper storage or transport
- improper or non-compliant use and maintenance (i. e. inconsistent with the manual)
- using the device in the improper conditions (too high humidity, too high or too low temperature, impact of the surrounding, sun etc.)
- unauthorized (by the user or other unauthorized persons) repairs, modifications or construction changes
- connecting equipment inconsistent with the technical documentation
- connecting additional equipment, which is not recommended by the producer
- improper power supply

c) elements which wear and tear such as discolor of the housing

If there is any of the above, claimant will be charged for transport and / or repairs.

VIII. Any changes in the Warranty Terms, improper use of the product (careless handling, exposure to liquids, moisture, corrosion), as well as traces of selfrepairing (non by the Reventon Group) or alterations cause, the warranty is not valid.

IX. Not following to any of warranty regulations makes the warranty not valid.

X. All correspondence, returns, complains should be send to the following address: Reventon Group Sp. z o.o. [Ltd.], 556 Wyzwolenia Street, 43-340 Kozy, Poland or email address: serwis@reventongroup.eu.

The producer reserves the rights to make changes to the technical documentation without previous notice.

Warranty card

| | |
|--|-------------------------------|
| Factory number of the device: | Address and place of assembly |
| Stamp and signature of the installation company: | |

Warranty form

| | | |
|---|--|---|
| The company reporting the complaint: | Date of assembly: | Address and place of assembly the device: |
| The company installing the device: | Date and circumstances of noticing the defect: | |
| | Factory number of the device: | Date of declaration the complaint: |
| Description of the defect: | | |
| Contact Name and Surname, telephone number/ e-mail address: | | |

Service card

| | | |
|------------------------------------|----------------------------|----------------|
| Date of declaration the complaint: | Description of the repair: | Service stamp: |
| Date of repair: | | |



reventon
INDUSTRIAL SOLUTIONS

Reventon Group Sp. z o.o. [Ltd.], 556 Wyzwolenia Street, 43-340 Kozy, Poland, www.reventongroup.eu